

M. Tverdostup

ABOUT SYNTHESIS OF INDUCTIVITY MULTIPLIERS BASED ON GENERALIZED MODEL OF IMPEDANCE CONVERTERS

Abstract. Using a generalized model of impedance converters converters of grounded and weighted inductances into a grounded inductance, in which separate control of the values of the components of the synthesized inductive impedance is implemented.

Keywords: synthesis, inductance, impedance, converter, operational amplifier, feedback, multiplier.

Introduction. The creation of functional devices for receiving and primary processing of information from passive measuring sensors is an urgent task. In some cases, to solve this problem, it is advisable to use impedance converters [1]. The development of impedance converters can be greatly simplified by having their basic model. In [2], a generalized model of impedance transducers is presented, which is promising for use as a base when creating the corresponding transducers for passive measuring transducer parameters.

Formulation of the problem. The aim of the work is to determine the possibilities of using a generalized model of impedance converters for the synthesis of multipliers of grounded and weighted (non-grounded) inductance.

Main part. Generalized model of impedance converters. In [2], it was shown that an operational amplifier with combined feedback (Fig. 1) has a functionally complete set of input impedances in the form

$$\dot{Z}_{in\bar{a}} = (Z_{i1} [- Z_{i2} Z_{i3}/Z_{i4}])/(1 - n), \quad (1)$$

$$\dot{Z}_{in\bar{b}} = (Z_{i3} [- Z_{i1} Z_{i4}/Z_{i2}])/(1 - l), \quad (2)$$

$$\dot{Z}_{in\bar{c}} = (Z_2 [- Z_{i1} Z_{i4}/Z_{i3}])/(1 - k), \quad (3)$$

$$\dot{Z}_{in\bar{z}} = (\dot{Z}_{14} [1 - \dot{Z}_{12} \dot{Z}_{13} / \dot{Z}_{11}] / (1 - p)), \quad (4)$$

where $\dot{Z}_1, \dot{Z}_2, \dot{Z}_3, \dot{Z}_4$ – are linear impedances of an arbitrary nature; U_1, U_2, U_3, U_4 - voltage of the excitation sources; $n = U_2/U_1, l = U_1/U_2, k = U_4/U_3,$

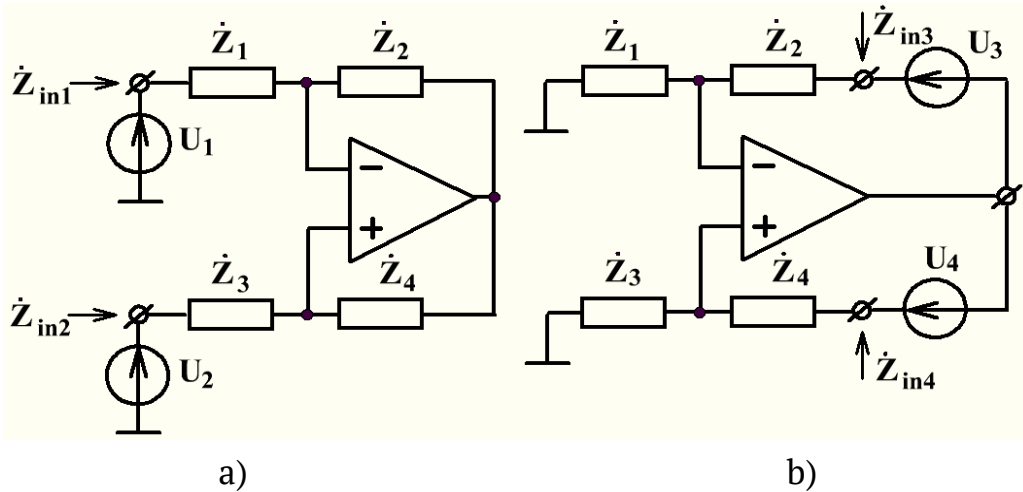

Figure 1 – Generalized model of impedance converters with grounded (a) and weighted (b) excitation sources

$p = U_3/U_4$. The values and signs of the components of the four possible input impedances $\dot{Z}_{in1} - \dot{Z}_{in4}$ are determined by the amplitude and phase relationships between the voltages of the excitation sources.

Synthesis of a grounded inductive impedance multiplier. We transform the grounded inductive impedance based on a generalized model with grounded excitation voltage sources (Fig. 1a) by choosing $\dot{Z}_1 = 0$ and $U_2 = 0$. Then it follows from (1) that $n = 0$, and the input impedance $\dot{Z}_{in\bar{z}}$ has the form:

$$\dot{Z}_{in\bar{z}} = \frac{-\dot{Z}_2 \dot{Z}_3}{\dot{Z}_4}. \quad (5)$$

In this case, with respect to \dot{Z}_2 and \dot{Z}_3 , the generalized model is a negative impedance converter, on the basis of which it is possible to multiply the inductive impedance by double converting it.

To implement double conversion, we select (Fig. 2) two series-connected negative impedance converters on DA1 and DA2, for which R_2, R_3, R_4, R_2, R_4 are used as linear impedances. The grounded inductance L_0

to be multiplied with the active resistance r_0 is included in the place of the grounded impedance Z_3 .

Under these conditions, the input impedance converter on DA2 according to (5) is equal to

$$Z_{in} = -\frac{R_2 (r_0 + j\omega L_0)}{R_4}, \quad (6)$$

it is converted with a change of sign by the DA1 converter to

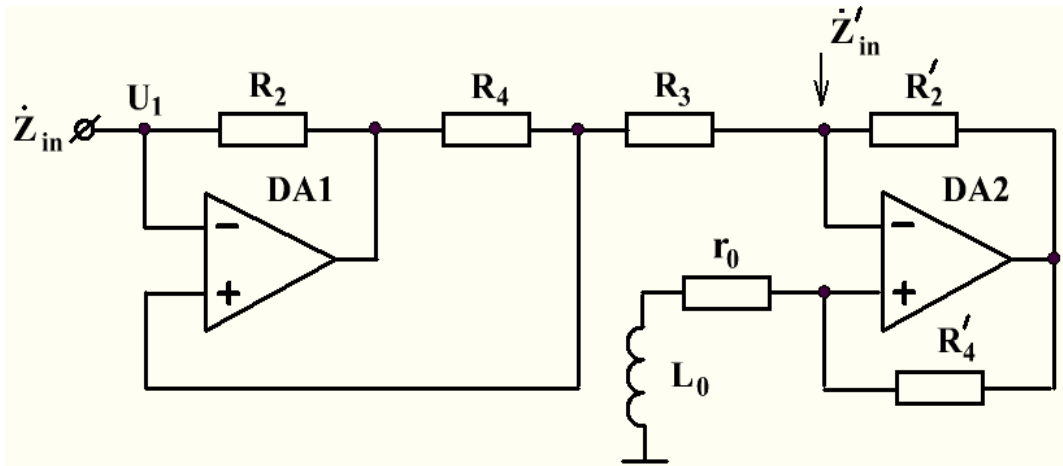

Figure 2 – The multiplier of the grounded inductance L_0 on two negative impedance converters

$$\dot{Z}_{in} = -\frac{R_2 (R_3 + \dot{Z}_{in})}{R_4}.$$

Then, taking into account (6), the input impedance of the DA1 converter becomes equal

$$\dot{Z}_{in} = -\frac{R_2 R_3}{R_4} + \frac{R_2 R_2 r_0}{R_4 R_4} + \frac{j\omega L_0 R_2 R_2}{R_4 R_4}. \quad (7)$$

The resulting input impedance $Z_{in} = r_{in}$ is inductive, represents a grounded inductance L_{in} with a series-connected active resistance r_{in} , the values of which are equal to (7)

$$r_{in} = \frac{R_2 \left(\frac{R_2 r_0}{R_4} - R_3 \right)}{R_4}, \quad (8)$$

$$L_{in} = \frac{L_0 R_2 R_2}{R_4 R_4}. \quad (9)$$

From the last expressions it follows that in this circuit, a grounded controlled inductance L_{in} is synthesized, the value of which is determined as the result of multiplying the inductance L_0 by the conversion coefficient equal to $\frac{R_2 R_2}{R_4 R_4}$.

The synthesized active resistance r_{in} can take both positive and negative values depending on the resistance value R_3 in comparison with $\frac{R_2 r_0}{R_4}$.

When the equality $R_3 = \frac{R_2 r_0}{R_4}$ is fulfilled, the input resistance, which minimizes the active losses of the synthesized inductance and significantly increases its quality factor.

Synthesis of a weighted inductive impedance multiplier. To build a non-grounded impedance multiplier, we select equation (1) for in-phase excitation voltages and $U_2 \ll U_1$. Then, from the generalized model (Fig. 1a), the variant of the multiplier in Fig. 3, wherein $\dot{Z}_1 = r_0 + j\omega L_0$ – complex impedance of multiplied inductance L_0 with active resistance r_0 ; R_2, R_3, R_4 – active resistances of the combined feedback circuit of the amplifier DA2.

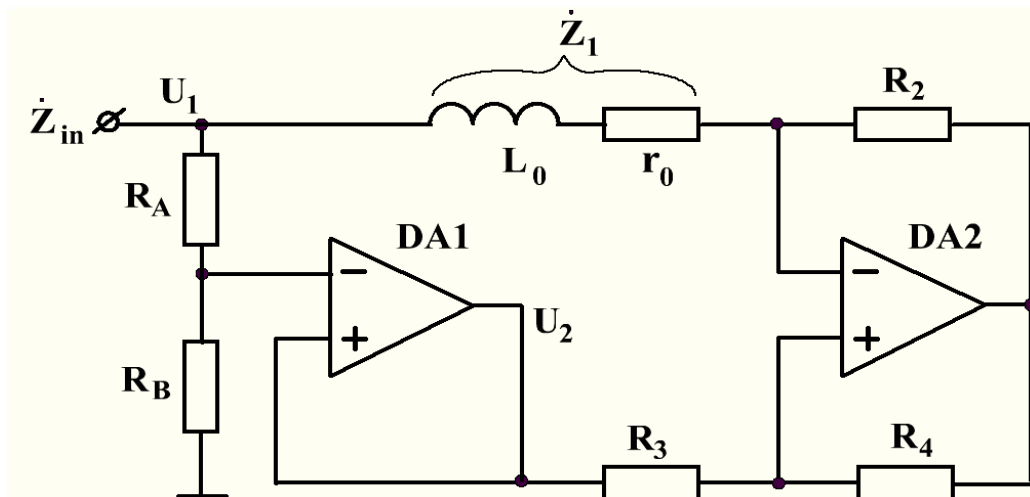

Figure 3 - Weighted inductance multiplier L_0 s active resistance r_0

The repeater on the amplifier DA1 with the divider RA, RB is an auxiliary device for the implementation of the excitation voltage source U_2 , in phase voltage U_1 . The ratio of the voltage of the excitation sources, in this case, has the form

$n = R_B / (R_A + R_B)$. Under such conditions, it follows from (1) that the input impedance of the circuit in Fig. 3 is equal

$$\dot{Z}_{in} = \left(\mathbf{1} + \frac{R_B}{R_A} \left/ (r_1 + j\omega L_1 - \frac{R_2 R_3}{R_4}) \right. \right). \quad (10)$$

In (10), we select the real and imaginary parts and obtain, respectively, the expressions for the input active resistance r_{in} and input inductance L_{in} as components of the synthesized input impedance \dot{Z}_{in}

$$r_{in} = \left(\mathbf{1} + \frac{R_B}{R_A} \right) \left(r_0 - \frac{R_2 R_3}{R_4} \right), \quad (11)$$

$$L_{in} = \left(\mathbf{1} + \frac{R_B}{R_A} \right) L_0. \quad (12)$$

It follows from (11) and (12) that the inductance L_0 and active resistance r_0 are converted into the input inductance L_{in} and resistance r_{in} with a

conversion coefficient $\left(\mathbf{1} + \frac{R_B}{R_A} \right)$, the value of which can be controlled over a wide range of resistances R_A, R_B of the divider. It also follows from (11) that the multiplication of the resistance r_0 is accompanied by its compensation of the negative active component of the input impedance $R_{(-)} = -\frac{R_2 R_3}{R_4}$, and if $R_{(-)} \rightarrow r_0$, then the input resistance $r_{in} \rightarrow 0$. This indicates a significant increase in the quality factor of the synthesized inductance.

Conclusions. As a result of the analysis established:

- synthesized multipliers of grounded and weighted inductive impedances are converters only to grounded impedance;
- the developed impedance multipliers allow separate control of the values of the synthesized inductance and its active resistance, which can take positive and negative values of a given value;
- a generalized model of impedance converters can be used as a basic circuit for constructing inductance multipliers.

ЛИТЕРАТУРА / ЛІТЕРАТУРА

1. Филановский И.М., Персианов А. Ю., Рыбин В.К. Схемы с преобразователями сопротивления. Л.: Энергия, 1973. 192 с.
2. Твердоступ Н.И. Обобщенная модель преобразователей импеданса. Вісник Дніпропетр. ун-ту. Фізика. Радіоелектроніка. 2010. Вип. 17, №2. С. 103 - 108.

REFERENCES

1. Fylanovskyi I.M., Persyanov A. Yu., Rybin V.K. Skhemy s preobrazovateliamy soprotivlenia. L.: Energia, 1973. 192 s.
2. Tverdostup N.I. Obobshchyonnaia model preobrazovatelej impedansa. Visnyk Dnipropetr. un-tu. Fyzyka. Radioelektronika. 2010. Vyp. 17, №2. S. 103 – 108.

Received 23.01.2020.
Accepted 28.01.2020.

О синтезе умножителей индуктивности на основе обобщенной модели преобразователей импеданса

На основе обобщенной модели преобразователей импеданса разработаны преобразователи заземленной и взвешенной индуктивностей в заземленную индуктивность, в которых реализовано раздельное управление величинами составляющих синтезированного импеданса.

Про синтез помножувачів індуктивності на основі узагальненої моделі перетворювачів імпедансу

На основі узагальненої моделі перетворювачів імпедансу розроблені перетворювачі заземленої і зваженої індуктивностей в заземлену індуктивність, в якій реалізоване роздільне управління величинами складових синтезованого імпедансу.

Твердоступ Николай Иванович - доцент, к.т.н., доцент кафедры электронных вычислительных машин Днепропетровского национального университета имени Олеся Гончара.

Твердоступ Микола Іванович – доцент, к.т.н., доцент кафедри електронних обчислювальних машин Дніпровського національного університету імені Олеся Гончара.

Tverdostup Mukola Ivanovich - Associate Professor of Computer Systems Engineering Department of the Oles Honchar Dnipro National University.